

# レギュレーター

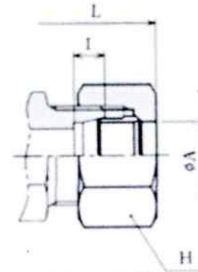
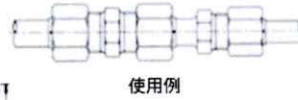
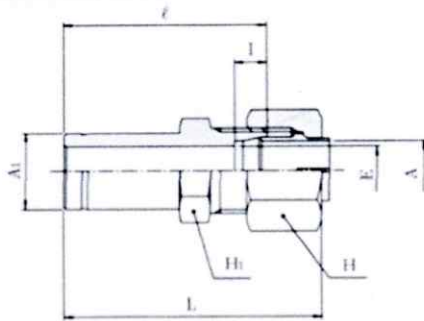

※印サイズの形状

単位：mm

継手の呼び	対応する 継手の呼び	A <sub>1</sub>	適用管外径 A		E	六角対辺		I	ℓ	手締め(約) L	重量 (kg)
			呼び径	外径		H <sub>1</sub>	H				
KRE08-060E	8	8	6	6	4	14	14	7	39	49.5	0.032
KRE10-060E	10	10	6	6	4	14	14	7	40	50.5	0.033
KRE10-080E	10	10	8	8	6	17	17	7	40	50.5	0.046
KRE12-060E	12	12	6	6	4	14	14	7	41	51.5	0.036
KRE12-080E	12	12	8	8	6	17	17	7	41	51.5	0.048
KRE12-100E	12	12	10	10	8	17	19	7	41	52.5	0.054
KRE15-080E	15	15	8	8	6	17	17	7	43	53.5	0.055
KRE15-100E	15	15	10	10	8	17	19	7	43	54.5	0.061
KRE16-060E	16	16	6	6	4	17	14	7	43	53.5	0.049
KRE16-100E	16	16	10	10	8	17	19	7	43	54.5	0.071
KRE16-120E	16	16	12	12	10	19	22	7	43	54.5	0.076
KRE18-100E	18	18	10	10	8	19	19	7	44	55.5	0.087
KRE18-150E	18	18	15	15	12	24	27	7.5	45	57.5	0.123
KRE20-060E	20	20	6	6	4	22	14	7	45	55.5	0.072
KRE20-120E	20	20	12	12	10	22	22	7	45	56.5	0.092
KRE20-160E	20	20	16	16	13	27	30	7.5	47	59.5	0.159
KRE22-150E	22	22	15	15	12	24	27	7.5	48	60.5	0.145
KRE22-180E	22	22	18	18	14	27	32	8	48	60.5	0.175
KRE25-160E	25	25	16	16	13	27	30	7.5	50	62.5	0.177
KRE25-200E	25	25	20	20	17	30	36	8	52	64.5	0.231
KRE28-180E	28	28	18	18	14	30	32	8	52	64.5	0.210
KRE28-220E	28	28	22	22	18	32	36	9	52	64.5	0.244
KRE30-200E	30	30	20	20	17	32	36	8	53	65.5	0.291
KRE30-250E	30	30	25	25	20	36	41	10	54	67.5	0.322
KRE35-220E	35	35	22	22	18	36	36	9	58	70.5	0.383
KRE35-280E	35	35	28	28	22	36	46	10	60	74	0.464
KRE38-250E	38	38	25	25	20	41	41	10	61	74.5	0.424
KRE38-300E	38	38	30	30	25	41	46	10	63	77.5	0.475
※KRE13-110N	13(1/4)	13.8	1/8	10.5	8	17	19	7	41	52.5	0.059
※KRE17-110N	17(3/8)	17.3	1/8	10.5	8	19	19	7	44	55.5	0.070
※KRE17-130N	17(3/8)	17.3	1/4	13.8	11	22	24	7.5	46	58	0.084
※KRE21-130N	21(1/2)	21.7	1/4	13.8	11	24	24	7.5	48	60	0.123
※KRE21-170N	21(1/2)	21.7	3/8	17.3	14	27	32	8	48	60.5	0.174
※KRE27-170N	27(3/4)	27.2	3/8	17.3	14	30	32	8	52	64.5	0.221
※KRE27-210N	27(3/4)	27.2	1/2	21.7	18	32	36	9	52	64.5	0.243
※KRE34-210N	34(1)	34.0	1/2	21.7	18	36	36	9	58	70.5	0.317
※KRE34-270N	34(1)	34.0	3/4	27.2	22	41	46	10	60	74	0.454

注. 予告なしに、品質・性能・改善のため寸法を変更する事があります。