

フィールドクランプ用ホース金具

金具形状

1004

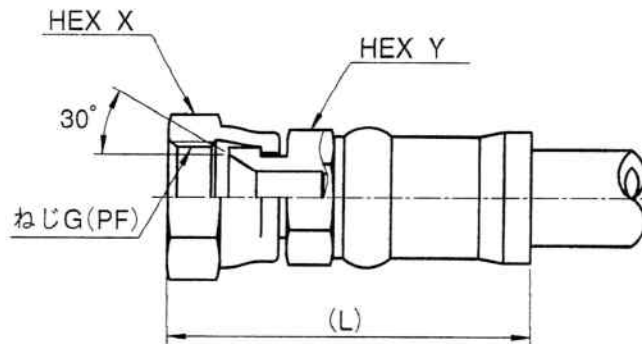

【特徴】

JIS B 8363

管用平行めねじメスシート

ホース内径	金具品番	ねじG(PF)	HEX X	HEX Y	L	備 考
6	GKC1004 6	1/4	19	17	55.5	
	GKC1004 -0204	1/8	14	17	53.5	
	GKC1004 -0604	3/8	22	19	57.5	
9	GKC1004 9	3/8	22	19	59.5	
	GKC1004 -0406	1/4	19	19	57.5	
	GKC1004 -0806	1/2	27	22	62.0	
	GKC1004 9AAA	1/4	19	19	57.5	
12	KKC1004 12	1/2	27	22	67.0	
	KKC1004 -0608	3/8	22	22	64.5	
	KKC1004 -1208	3/4	36	30	72.0	
15	GKC1004 -0810	1/2	27	30	81.0	
	GKC1004 -1210	3/4	36	30	83.0	
19	GKC1004 19	3/4	36	30	89.5	
	GKC1004 -0812	1/2	27	30	87.5	
	GKC1004 -1612	1	41	36	91.5	
	GKC1004 19AAA	3/4	36	30	89.5	技研向ケーブル保護用 内径16.5mm
25	GKC1004 25	1	41	36	98.5	
	GKC1004 -2016	1 1/4	50	46	104.0	
32	GKC1004 32	1 1/4	50	46	122.0	
	GNC1004 32	1 1/4	50	46	110.0	
38	GKC1004 38	1 1/2	60	50	142.0	
	KKC1004 38	1 1/2	60	50	144.0	280kgf/cm ² 迄使用可能
	GNC1004 38	1 1/2	60	50	118.0	
50	GKC1004 50	2	70	65	165.0	
	KKC1004 50	2	70	65	165.0	
	GNC1004 50	2	70	65	132.0	